

**YELLO**<sup>TM</sup>  
EQUIPMENT



# WHEN MANOEUVRABILITY MATTERS

SMALL. POWERFUL. PRACTICAL IN SMALL SPACES.



**MINI EXCAVATOR**  
**SY26U** **SANY**  
Quality Changes the World

Engine  
Yanmar 3TNV80F

Engine power  
15.2 kW/2500

rpm Bucket capacity  
0.06 m<sup>3</sup>

Weight  
2760 kg

# SANY

## SY26U

### Challenging tasks call for a first-class partner

Quality comes from experience. And from new ideas. This is why we combine these two crucial factors at SANY. We are one of the world's leading producers, having sold more than **170,000** excavators in **10 years**. This means that you can always rely on sophisticated products that have been tried and tested in practice. And on the latest innovative technology. An impressive **5–7%** of our annual turnover is dedicated to research and development. This is why we give you not only our word, but also our extraordinary **five-year warranty** as a guarantee of how powerful and robust our products are.

**170.000**  
EXCAVATORS SOLD IN  
**10 YEARS**

**5–7%**  
TURNOVER FOR RESEARCH  
AND DEVELOPMENT

UP TO  
**FIVE-YEAR**  
WARRANTY

QUALITY CHANGES THE WORLD



#### SY26U HARD FACTS

Bucket digging force (ISO)  
27.4 kN

Arm digging force (ISO)  
14.39 kN

Swing speed  
10 rpm

Max. travel speed  
4.5 km/h

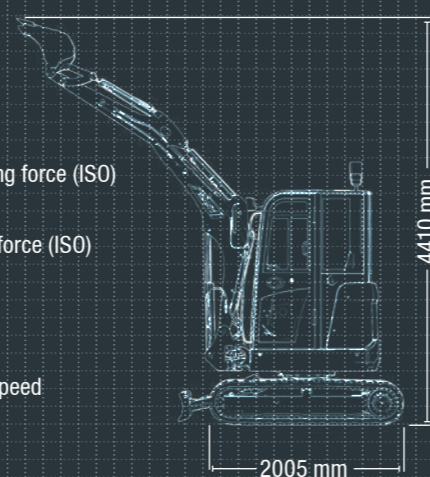

## THE MOST COMPACT COMBINATION OF PERFORMANCE AND FUNCTIONALITY

SANY's small models have always punched above their weight when it comes to cost-effectiveness and efficiency – and the new SY26U mini excavator is no different. It is in its element wherever speed and power need to be displayed, even when space is tight.

Its manoeuvrability and extremely precise control are also impressive in road construction, horticulture and landscaping. The new small model shows its strengths even when just travelling to the workplace, as its comparatively low weight and compact dimensions allow for fast and safe loading and unloading.



EFFICIENT AND COST-EFFECTIVE

**SY26U**

# WHEN MOBILITY AND POWER COME TOGETHER

The new SY26U boasts an extremely compact design. Its minimal turning radius without tail swing and the boom swivel cylinder enable the excavator to use its full power in the smallest of spaces.



## For clever calculations – cost-effectiveness made easy

The new SY26U boasts a whole host of properties that allow you to make crucial savings. For example, the advanced LS hydraulic system, integrated power control and operating mode selection improve speed and performance while reducing fuel consumption.

TOP FEATURES

### ENGINE POWER

The successful Yanmar T4F engine guarantees **reliable performance**, even in difficult working conditions.

### DURABILITY

The reinforced structure **improves stability** and **extends the service life**.

### FUEL CONSUMPTION

The intelligent control system adapts the pump capacity to the available engine power for **greater efficiency** and **reduced fuel consumption**.

### HYDRAULIC SYSTEM

Load-sensing hydraulic system for outstanding **efficiency** and **performance**.



### VARIETY OF APPLICATIONS

Standard connections provide many options for adding **accessories from any manufacturer** for various applications.

### ORIGINAL ACCESSORIES

SANY original parts and accessories represent **maximum availability**. Continuous certified quality comes guaranteed!

### MAINTENANCE INTERVAL

Long maintenance intervals ensure **high cost-effectiveness** as a result of **more efficient and safer machines**.

### EASE OF SERVICING

The large engine bonnet and the clear arrangement of the key components in the centre make **maintenance and service quick and easy**.

## METAL PANELS = DURABLE AND RECYCLABLE

From the choice of materials and the design, right through to the workmanship, SANY aims to make all its mini excavators durable and robust. For example, all panels are made solely of metal, which makes them extremely long-lasting.



## Absolute reliability – for peace of mind!

SANY's five-year warranty\* gives you the peace of mind that you can fully count on your equipment.

\* With participating partners



**Convenient maintenance is at the top of the agenda thanks to rear access**

The large engine bonnet and the clear arrangement of the key components in the centre make maintenance and service quick and easy: The air filter, water separator, oil dipstick, expansion vessel and oil filler neck are especially easy to reach.



**Operating excavators with unobtrusive view – truly impressive**

A good view of outside is indispensable if you are to perform your work accurately and quickly. The SY26U's canopy offers the operator a wide field of view, allowing them to keep an eye on all areas and work steps at all times. The entire work area can be controlled with ease thanks to the large front, side and rear windows, without the driver having to get out of their seat.



**The added benefits SANY offers you:**

- + Quiet and low-vibration engine
- + Responsive, precise control
- + Ergonomic, comfortable seat
- + Clear displays
- + Optimal visibility on all sides
- + Heater
- + TOPS and OPG-tested

**TOP MARKS FOR YOUR NEW WORKPLACE**

Safety, comfort, ergonomics... this cockpit has everything you need to make your day-to-day work more convenient and simple. This starts when you enter the canopy, which you can do comfortably and safely. And after that? Handling is simply effortless. Not only because the interior has a carefully considered

ergonomic design but also because it offers you a lot of scope to respond. In addition, all displays can be read effortlessly on the large, high-resolution colour screen, while the wide field of view provides you with perfect visibility on all sides. But you don't need to take our word for it...



**More space for you!**

The high-quality ergonomic seat is not only comfortable to sit on, it also provides you with unusually generous legroom

sophisticated damping, provides additional comfort by reducing cab vibrations and lowering the noise level.

**Operation – designed with generous dimensions**

Maximum operating convenience awaits, since the controls are arranged so that they are within easy reach. The easy-to-read display provides you with all the essential information at a glance.

## ENGINE

Model	Yanmar 3TNV80F
Type	Water-cooled four-stroke diesel engine with turbulence chamber fuel injection
Rated power	15.2 kW/2500 rpm
Max. torque	64.7 Nm/1800 rpm
Displacement	1.267 l
Batteries	1x 12 V/55 Ah

## HYDRAULIC SYSTEM

Main pump	1x variable displacement axial piston pump
Maximum oil flow	1x 72 l/min
Travelmotor	2x variable displacement axial piston engines
Swingmotor	1x variable displacement axial piston engine

## RELIEF VALVE SETTINGS

Implement circuit	245 bar
Swing circuit	196 bar
Travel circuit	245 bar
Pilot circuit	35 bar

## SERVICE REFILL CAPACITIES

Fuel tank	34 l
Engine coolant	4.1 l
Engine oil	3.4 l
Final drive (per side)	0.6 l
Hydraulic system	45 l
Hydraulic oil tank	30 l

## PERFORMANCE

Swing speed	10 rpm
Travel Speed	High: 4.5 km/h, low 2.4 km/h
Max. travel force	20 kN
Gradeability	25 %
Bucket digging force (ISO)	27.4 kN
Bucket digging force (SAE)	24.2 kN
Arm digging force (ISO)	14.39 kN
Arm digging force (SAE)	13.83 kN

## LOWER AND UPPER STRUCTURE

Rotation device	Axial piston engine with planetary gear running in oil bath and single-row slewing ring. Spring-loaded slewing gear parking brake, hydraulically released.
Undercarriage	Reinforced, large lower structure Welded running gear frame with modular design, made from a special material. Side frame welded to the running gear frame.

## LIFTING CAPACITIES OF LOWER DOZER BLADE

Load point height	Radius				Horizontal reach			
	2.0 m/6.6 ft	3.0 m/9.8 ft	4.0 m/13.1 ft	Maximum				
4.0 m kg					693	584		
13.1 ft lb					1525	1285		
3.0 m kg	623	470			540	365		
9.8 ft lb	1373	1034			118	803		
2.0 m kg	707	459	501	282	493	282		
6.6 ft lb	1558	1010	1102	620	1085	620		
1.0 m kg	937	421	717	274	507	256		
3.3 ft lb	2061	926	1577	603	1115	563		
Ground line kg	1521	715	1095	398	732	267	582	263
Ground line lb	3346	1573	2409	876	1610	587	1280	579
-1.0 m kg	1807	722	1012	395			730	316
-3.3 ft lb	3975	1588	2226	869			1606	695
-2.0 m kg	883	786					609	576
-6.6 ft lb	1943	1729					1340	1267

## LIFTING CAPACITIES OF UPPER DOZER BLADE

Load point height	Radius				Horizontal reach			
	2.0 m/6.6 ft	3.0 m/9.8 ft	4.0 m/13.1 ft	Maximum				
4.0 m kg					693	584		
13.1 ft lb					1525	1285		
3.0 m kg	564	470			438	365		
9.8 ft lb	1241	1034			963	803		
2.0 m kg	549	459	340	282	340	282		
6.6 ft lb	1208	1010	748	620	748	620		
1.0 m kg	515	421	332	274	310	256		
3.3 ft lb	1133	926	730	603	682	563		
Ground line kg	910	715	488	398	324	267	320	263
Ground line lb	2002	1573	1074	876	713	587	704	579
-1.0 m kg	917	722	485	395			385	316
-3.3 ft lb	2017	1588	1067	869			847	695
-2.0 m kg	883	786					609	576
-6.6 ft lb	1943	1729					1340	1267

## DIMENSIONS

A Transport length	4285 mm
B Transport width	1550 mm
C Upperstructure width	1375 mm
D Height over cab	2430 mm
E Transport height	1620 mm
F Overall length of crawler	2005 mm
G Tail length	775 mm
H Track gauge	1250 mm
I Undercarriage width (blade)	1550 mm
J Horizontal distance to blade	2940 mm
K Blade height	300 mm
L Track height	445 mm
M Track width	300 mm
N Minimum ground clearance	290 mm
O Counterweight clearance	555 mm
P Engine cover height	1460 mm
Q Tail swing radius	775 mm
R Center distance of tumbler	1560 mm

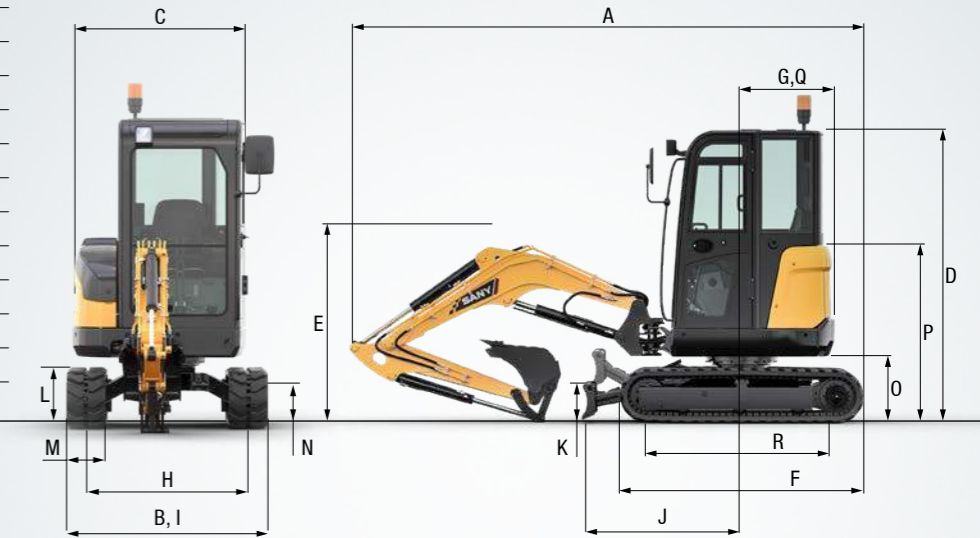

## OPERATING RANGE

A Max. digging reach	4740 mm
B Max. digging depth	2820 mm
C Max. digging height	4410 mm
D Max. dumping height	3100 mm
E Min. dumping height	940 mm
F Max. vertical digging depth	2585 mm
G Overall height over arm by Min. swing radius	3200 mm
H Arm head distance with work equipment retracted as far as possible	1530 mm
I Swing radius by minimum boomswing / Swing radius by maximum boomswing	L 1795 mm R 1815 mm
J Max. clearance when blade up	360 mm
K Max. depth of blade down	330 mm
L Max. boom-swing angle	L 540 mm R 765 mm
Max. boom-swing angle (deg.)	L 67° R 51°

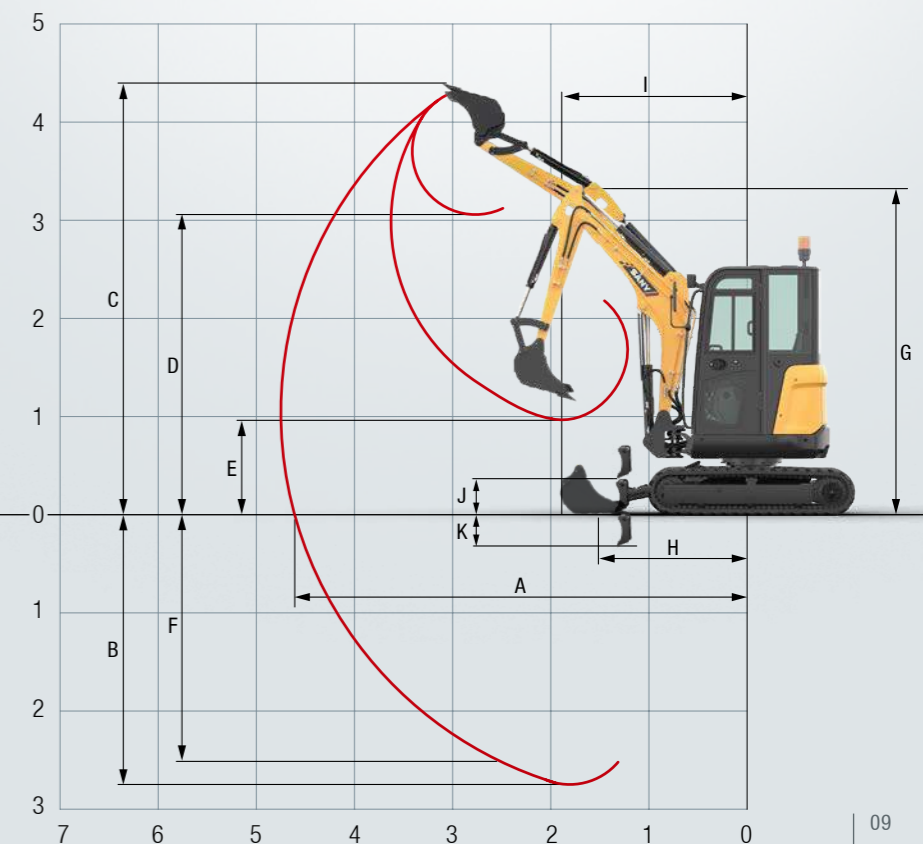
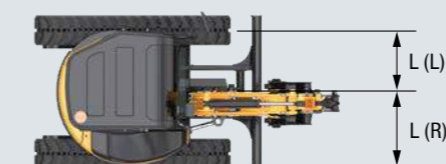

### Powerful and mobile – the SY26U is well-equipped by its very nature!

It has everything it needs to become an indispensable aid. Its impressive properties include not only its power and endurance, but also the boom arm's precise response characteristics thanks to the sophisticated hydraulic system. Outstanding performance for a fair price: That's what we call cost-effective.



#### ENGINE

Engine oil filter (cartridge)	●
Main fuel filter	●
Coolant expansion tank	●
Water separator for engine fuel system	●
Air filter	●

#### HYDRAULIC SYSTEM

Full flow filter	●
Hydraulic pilot control lever	●
Pilot control switch-off lever with neutral shifting	●
Pilot control circuit filter	●
Suction filter	●
Stewing gear parking brake	●
Two-stage ground drive	●
2x double-acting hydraulic circuits for attachment devices	●

#### UPPER STRUCTURE

Additional relief valve	●
Counterweight (cab/four-column protective roof): 210 kg	●
Pilot control circuit accumulator	●

#### LOWER STRUCTURE

Rubber chain 300 mm	●
---------------------	---

Standard option ●    Option ●

The standard and special options differ depending on the country in which the mini excavator is delivered. If you have any questions, please contact your dealer directly.

#### CAB/FOUR-COLUMN PROTECTIVE ROOF

FM radio (cab only)	●
Anti-slip step	●
Armrests	●
Defroster (cab only)	●
Drinks holder	●
Electric double horn	●
Floor mat	●
Heater (cab only)	●
Seat belt	●
Windscreen washer system (cab only)	●
Windscreen wiper (cab only)	●
Suspension seat	●
Single-acting/double-acting additional control circuit (AUX 1) activated by proportional control in pilot control lever	●
Double-acting additional control circuit (AUX 2) activated by proportional control in pilot control lever	●
8x additional circuit flow adjustment via on-board computer with multifunctional monitor	●

#### WORK EQUIPMENT

Arm: 1300 mm	●
Boom: 2100 mm	●
First proportional additional control circuit	●
Second proportional additional control circuit	●
Boom & arm safety lifting valves with indicator	●
Circuit for hydraulic quick couplers	●

## A SERVICE YOU CAN RELY ON

Just as we do with our excavators, we demand high quality and reliability of our service products. This underlines our equipment's performance in terms of durability and their excellent price-performance ratio. After all, maintenance is crucial for

efficiency, cost-effectiveness and safety. Your SANY dealer is happy to help you with a comprehensive range of services to ensure that your machine continues operating efficiently in the long term.

### SANY – flexible, fast and always there for you

Rapid assistance, tailored advice and a reliable supply of original parts – that is what we mean by a premium service.



## NSW



### The added benefits SANY offers you:

#### The added benefits SANY offers you:

- + Fast supply due to central located parts warehouses
- + More than 15,000 spare parts to make your machine highly reliable
- + Expert knowledge for optimal supply for your machine
- + Thanks to SANY's special training programme, our dealers are always kept up-to-date so that they can face all technical challenges.

### Parts supply – fast and inexpensive

By purchasing a SANY mini excavator, you have invested in the future. Fast availability of spare parts is your guarantee of minimal downtimes and failure times.

### Detailed information in black and white

Handbooks and documents are available for all SANY mini excavators, and these can help you with operation, maintenance, servicing and repairs. These include operating and maintenance instructions and technical specifications.



# COMPACT POWER- HOUSE FOR THE FINER DETAILS

Intricate tasks on construction sites in towns and cities or in horticulture and landscaping depend on manoeuvrability and precise control. This, combined with a great deal of power, makes the SY26U a high-quality, powerful machine and therefore a reliable partner for you.

## EXTREMELY COMPACT

Thanks to its compact design, the SY26U greatly simplifies working on confined construction sites.

## ON-SITE IN NEXT TO NO TIME

Small and compact – ideal prerequisites which the SY26U fulfils in order to be transported with a 3.5 t trailer.

## DURABLE AND ROBUST

Reinforcements and protective elements at the relevant points and panels consisting solely of metal allow you to plan for the long term.

## OUTSTANDING COST-EFFECTIVENESS

Countless details, such as the sophisticated LS hydraulic system and the fact that the fuel consumption is reduced while the speed and performance remain the same, make the SY26U extremely efficient.

## VERY CONVENIENT OPERATION

The driver's cab is spacious and easy to access, and features ergonomically adapted controls, providing increased comfort for the driver operating the SY26U.

## EASY TO MAINTAIN

Easy-to-reach components simplify service work on the SY26U, including when this is performed on-site.

## WELL-EQUIPPED

The SY26U features extremely extensive equipment, even in the standard version. This can be upgraded with additional special options and adapted to individual requirements.

## POWERFUL DOWN TO THE SMALLEST DETAIL

The Yanmar T4F engine guarantees reliable performance and, thanks to its intelligent control system and adapted pump capacity, is completely ready for use in any situation.

## TOP TECHNICAL PROPERTIES

Engine	Yanmar 3TNV80F
Engine power	15.2 kW/2500 rpm
Max. torque	64.7 Nm/1800 rpm
Max. travel speed	4.5 km/h
Swing speed	10 rpm
Main pump	Variable displacement axial piston pump
Maximum oil flow	72 l/min

Not all products are available in all markets. As part of our continuous improvement process, we reserve the right to modify specifications and designs without giving prior notice. The figures may contain additional options.

**YELLO EQUIPMENT**

**SANY AUTHORISED DEALER**

P: 1300 093 556

W: [YELLOEQUIPMENT.COM](http://YELLOEQUIPMENT.COM)

**YELLO**<sup>TM</sup>  
EQUIPMENT